

# Servo

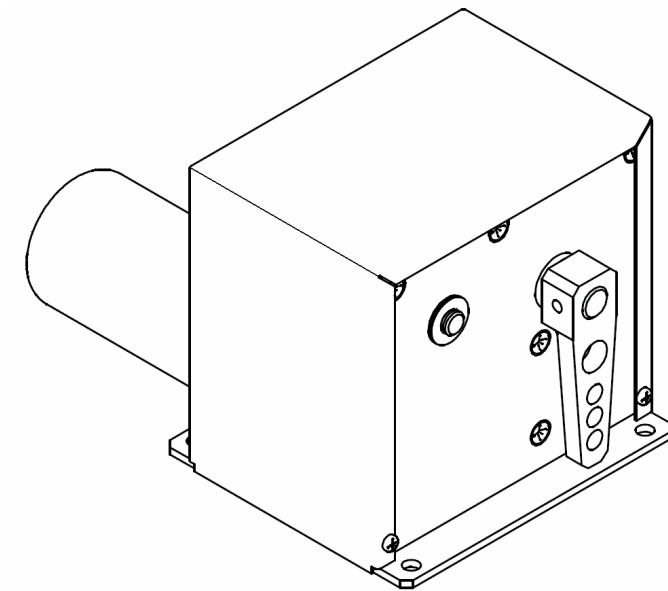

## Installation Manual



P/N: TLX-6550-DI-001\_PrA

Copyright 2008-2009  
TL elektronik  
All Rights Reserved

Except as expressly provided below, no part of this manual may be downloaded, transmitted, copied, reproduced, disseminated or stored in any storage medium, for any purpose without the express prior written consent of the TL elektronik company. Address your questions about the technical information to TL elektronik. Other information about sale, distribution should be directed to our exclusive distributors (see World Distributor list on our website).

Producer's address:  
TL elektronik Inc.  
Airport, Building 125,  
503 41 Hradec Kralove, Czech Republic  
Fax: +420 49 548 23 94 E-mail: [info@tl-elektronik.com](mailto:info@tl-elektronik.com)  
Web Site Address: [www.tl-elektronik.com](http://www.tl-elektronik.com)

Please, send your e-mail address to [customer@tl-elektronik.com](mailto:customer@tl-elektronik.com) to receive the latest information about software upgrade.

Send your ideas to [innovation@tl-elektronik.com](mailto:innovation@tl-elektronik.com)  
We will evaluate your suggestion and provide an update.

Windows is registered trademark of Microsoft Corporation.  
All trademarks and registered trademarks are acknowledged.  
ScheckK® is registered trademark of TL elektronik.  
iFamily® is registered trademark of TL elektronik.  
sModern® is registered trademark of TL elektronik.

All information in this User's manual is subject to change without prior notice.

## Table of contents

<b>TABLE OF CONTENTS</b> .....	<b>II</b>
<b>1 REVISION TABLE</b> .....	<b>1-1</b>
<b>2 GENERAL DESCRIPTION</b> .....	<b>2-1</b>
2.1 GENERAL INFORMATION.....	2-1
2.2 LIMITED WARRANTY.....	2-2
<b>3 TECHNICAL SPECIFICATIONS</b> .....	<b>3-1</b>
<b>4 INSTALL RECOMMENDATION</b> .....	<b>4-2</b>
4.1 INTRODUCTION.....	4-2
4.2 LOCATION CONSIDERATION.....	4-2
4.3 INSTALLATION.....	4-2
4.4 RECOMMENDED WIRING PRACTICES.....	4-3
4.5 HARNESS MATING.....	4-3
4.6 POWER REQUIREMENTS.....	4-3
4.7 WIRING OVERVIEW.....	4-3
4.8 SAFETY FEATURES.....	4-4
4.8.1 <i>Emergency Disconnect</i> .....	4-4
4.8.2 <i>Data Delay Disconnect</i> .....	4-4
<b>5 MECHANICAL DRAWING</b> .....	<b>5-1</b>
5.1 FRONT VIEW.....	5-1
5.2 SIDE VIEW.....	5-1
5.3 TOP VIEW.....	5-1
<b>6 ELECTRICAL DRAWING</b> .....	<b>6-2</b>
6.1 PIN FUNCTION LIST.....	6-2
6.1.1 <i>Power Supply and Accessories Interconnect</i> .....	6-3
<b>7 CONCLUSION</b> .....	<b>7-1</b>



## 2 General description

### 2.1 General Information

The TL elektronik servo has a 360-degree turn capability which can provide an unlimited turn range. This allows the servo to be installed in a range of positions in relation to the lever. However the controlled angle is 350-degrees. Refer to picture on page 2-1.

TL elektronik servos are dimensionally similar to other leading servos.

The main frame and cover is made of aluminum; the shafts of the servo are constructed of stainless steel. The Servo is powered by a powerful compact electro-drive combined with a three stage planetary gearbox. The torque moment is then distributed to the electromagnetic clutch, from which it is applied via additional gearing to the servo lever. An advantage of the servo is that electromagnetic clutch torque can be controlled remotely.

The servo is controlled by a microprocessor enabling bidirectional communication between servo and autopilot. This makes the servo an active, intelligent extension of the autopilot.

For aircraft that TL elektronik has not yet developed a specific mounting kit, TL elektronik has developed a generic kit that includes rod ends and other servo attachment hardware. Note that if you use this kit, you will need to determine an adequate location and mounting method for installing your servos.

**NOTE:** If you doubt your expertise in servo installation or you do not want to use the generic kit please contact your aircraft manufacturer for model specific TL elektronik servo kit.

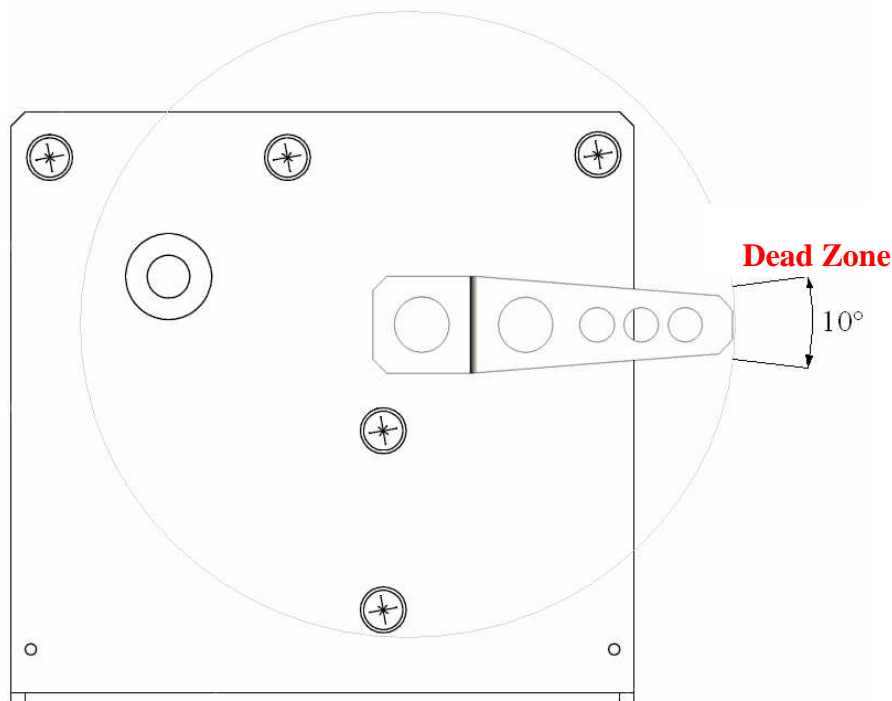

## 2.2 *Limited Warranty*

This manual contains important information that may affect the safety of the pilot, passengers, aircraft and operation of the system or time to install the system. You **MUST** read the manual prior to installing this system. Any deviation from these installation instructions is the sole responsibility of the installer and should be done in accordance with AC 43.13. Read the Warranty/Agreement. There is information in the Warranty/Agreement that may alter your decision to install this product. If you do not accept the terms of the Warranty/Agreement, do not install this product. This product may be returned for a refund. Contact TL elektronik Inc. for details.

 **WARNING:** If the installer does not have the skills, knowledge, tools, equipment or facility, to perform and determine whether the installation of this product is safe, reliable and accurate and to determine whether this product is operating properly after installation, **DO NOT INSTALL THIS PRODUCT**. If the owner/pilot and/ or installer are unwilling to take the responsibility for the installation and operation of this product, **DO NOT INSTALL THIS PRODUCT**. This product may be returned for a refund. Contact TL elektronik Inc. for details.

 **NOTE:** By installing this product, the aircraft owner/pilot and installer agrees to hold TL-elektronik Inc. in no way responsible for monetary compensation, including punitive damages for any incident, harm and/or damage associated with this product. If you do not agree to the above, **DO NOT INSTALL THIS PRODUCT**. This product may be returned for a refund. Contact TL elektronik Inc. for details.

 **NOTE:** TL-elektronik Inc. is not liable or responsible for a pilot's action or any situation that results in personal injury, property damage, missed commitments, lack of use of an aircraft or any expenses incurred due to: product failure, inaccuracy in data provided, format issues, software bugs or problems, upgrade or customization issues, misinterpretation of data, calibration problems, installation issues (leaks, incorrect wiring, obstructions, damage to aircraft or components, incorrect installation of any parts, wrong parts, parts that don't fit, etc.) or any other issues related to the installation or operation of this product. All of the above are solely the pilot's and/or installer's responsibility. The pilot must understand the operation of this product before flying the aircraft. The pilot will not allow anyone to operate the aircraft that does not know the operation of this product.

 **WARNING:** Do not install a non-certified Servo in a certified aircraft.

### 3 Technical Specifications

#### Physical characteristic

Width	88,5 mm	3,48"
Height	83,8 mm	3,3"
Depth	135,5 mm	5,33"
Weight	0,8 kg	1,76 lbs

#### General Specifications

Operating Temperature Range	- 20°C to +55°C
Humidity	95% non-condensing
Altitude Range	7620 meters max (25000 feet max)
Vibration	5 to 500 Hz
Control angle range of the lever	min ± 350°
Uncontrolled angle range of the lever	85°/s to 95°/s
Dimensions of Connection Holes on the Lever	Ø 5mm hole spacing 1,000; 1,250 and 1,500 inch (See figure 5.1)
Torque moment	4,3 Nm / 38,06 lbf-in

#### Electric Specifications

Power Range	12 Volts
Power Consumption (Standby Mode – Autopilot Disconnected)	75 mA @ 12 Volts
Power Consumption (Operating Mode – Autopilot Connected)	Max.1400 mA @ 12 Volts

#### Communication

CAN BUS	1 Mb/s
---------	--------

## 4 Install Recommendation

### 4.1 Introduction

Careful planning and consideration are required to achieve the desired performance and reliability from the Servo. The performance and reliability of the servo is determined by careful planning and consideration in its installation. Please follow the suggested guidelines

### 4.2 Location Consideration

For proper servo operation, the servo must be mounted in a location which assures proper interaction with the existing control system.

This location must permit the servo lever and associated linkage to move freely through the entire range of motion. To prevent the possibility of the servo lever going over center, the servo lever must not turn more than a total of  $\pm 60^\circ$  from neutral position throughout the control system's range of motion.

### 4.3 Installation

The diagram below shows the outer dimensions of the Servo.

The TL electronic servo mounting kit includes some of the basic hardware to mount and connect servo to the aircraft control system. This kit can be used in either pitch roll or yaw applications that use a servo with an output lever.

Once a mounting location has been determined, the next step is to fabricate a servo mount to attach it to the aircraft. This attachment can be done with a bracket made of sheet metal or corner stock. We recommend using aluminum with a proper thickness for the best balance of strength to weight. When fabricating a mounting bracket take the servo dimensions into consideration.

Leave enough room to permit the lever and attached linkage to move through a complete range of motion. We recommend that all 4 of the include screws be installed with star washers and flat washers to secure the servo to a mounting bracket. All screws supplied by TL elektronik have drilled heads for use with safety wire. The final method for mounting the servo/bracket in the aircraft is to be determined by the installer.

The distance between the servo lever and the control system attachment point must allow for the angle between the servo lever and the push rod to be at approximately  $90^\circ$  when the controls are at neutral.

When using the TL elektronik mounting kit, we suggest first installing the linkage on one of three holes on the servo lever.

Pay attention to the table below illustrating the maxim load that can be applied to each position on the lever.

<b>Position (inch)</b>	<b>Max. Load</b>
1,000	169,3N / 38,06 lbf
1,250	135,4N / 30,44 lbf
1,500	112,9N / 25,38 lbf

Changing this location will affect servo torque output, servo lever motion, control surface resolution, and the amount of force required to shear the safety screw, and should only be done if the installer has an understanding of these implications.

#### ***4.4 Recommended Wiring Practices***

For all electrical connections, use correct wiring techniques, taking care to properly insulate any exposed wire or cables. A short circuit between any of the wires may cause damage to the Servo and/or your aircraft. Make all connections to your harness before connecting it to any of the components of the system. Do not make connections while the Servo is turned on or power is applied to any point in the system. We recommend that all wire you use also meets 20 AWG Mil Standard MIL-W-22759/16. When using any pre-manufactured harness, verify that each pin has continuity with the expected wire on the wiring diagram. This test can be easily done with a multi-meter. When verifying harnesses. Use the wiring charts and diagrams in this guide. Use appropriate strain relief at all junctions between wires and connectors. We recommend that you secure all wires at regular intervals along wiring runs to accommodate vibration effects.

#### ***4.5 Harness Mating***

The following diagram 6.1.1 on page 6-3 shows the connector on the Servo. The connector is used for communication with the other equipment.

#### ***4.6 Power Requirements***

20 AWG wire is normally sufficient for the power supply and grounding, but we recommend that you consult a wire sizing chart and determine the size required for the wire routing in your particular aircraft. Ensure that the power supply include a circuit breaker

#### ***4.7 Wiring Overview***

The Servo power requirement is as low as 3 amps in a 12/24 volt system. And therefore you can use a 3-amp circuit breaker. See the technical specification chart for details.

## **4.8 Safety Features**

### **4.8.1 Emergency Disconnect**

The Emergency Disconnect Switch is a failsafe system. Flipping the switch disconnects power to the Auto Pilot servo and disables the Electro-Magnetic clutch. This instantly restores full control of the aircraft to the pilot in the event of instrument or system malfunction.

The Emergency Disconnect Switch is an essential part of the TL electronic autopilot system. Its installation is mandatory.

### **4.8.2 Data Delay Disconnect**

In the event the Auto Pilot Servo does not receive data or the digital information stream is cut off from the Integra/Autopilot. The autopilot servo will automatically disconnect restoring full control of the aircraft to the pilot.

## 5 Mechanical Drawing

### 5.1 Front View

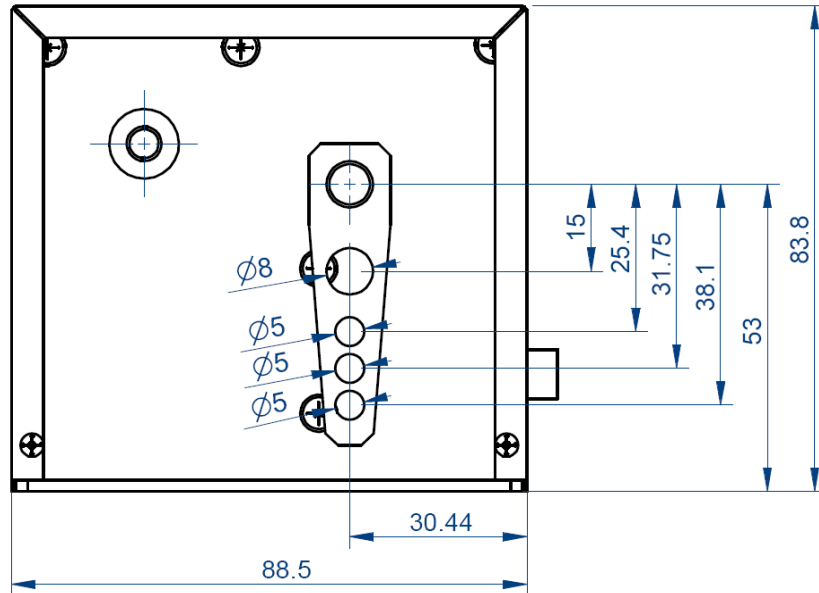

**NOTE:** All measurements are in millimeters

### 5.2 Side View

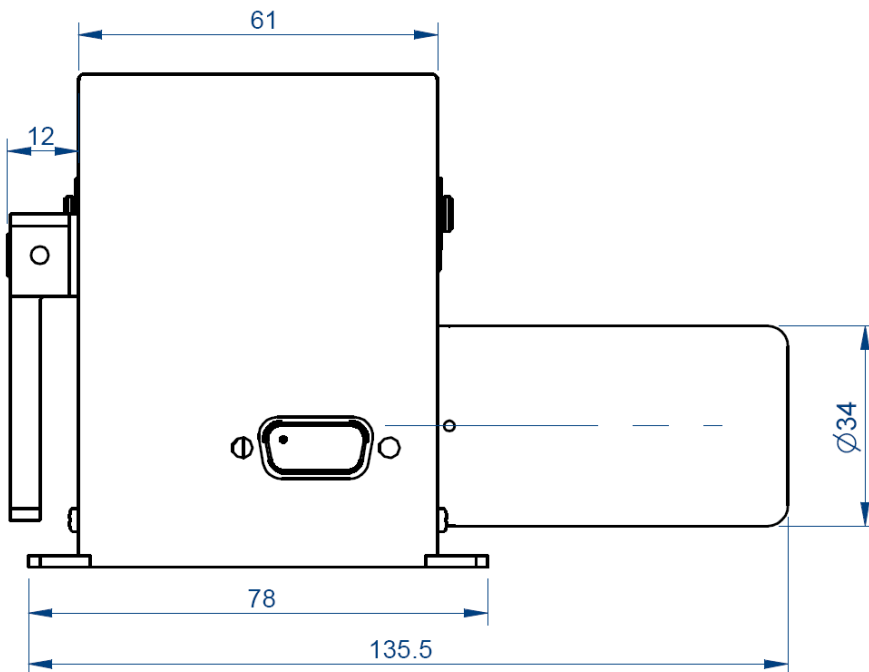

**NOTE:** All measurements are in millimeters

### 5.3 Top View

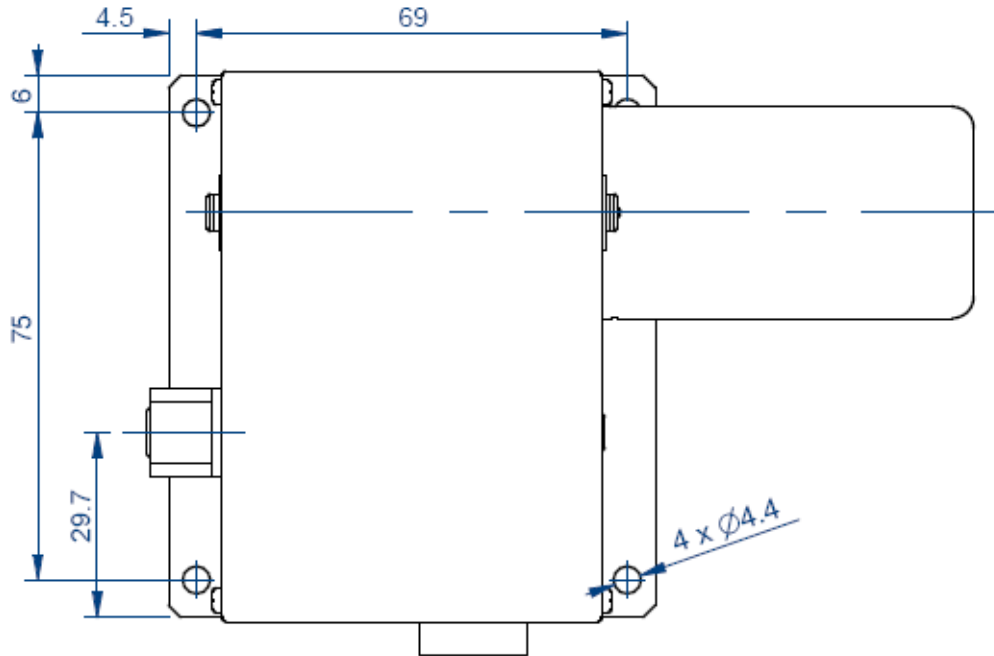

**NOTE:** All measurements are in millimeters

## 6 Electrical Drawing

### 6.1 PIN FUNCTION list

**Complementary accessory** – type: D-SUB9 – Female (connector to Servo)

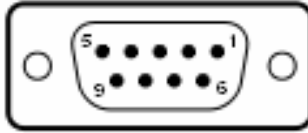

**Main Connector** – type: D-SUB9 – Male (connector on Servo)

Pin	Pin Name	I/O
1	Aircraft Power	In
2	N/A	--
3	N/A	--
4	Do not connect!	--
5	Aircraft Ground	--
6	Aircraft Power	In
7	iFamily® Bus (CANH)	In/Out
8	iFamily® Bus (CANL)	In/Out
9	Aircraft Ground	--

### 6.1.1 Power Supply and Accessories Interconnect

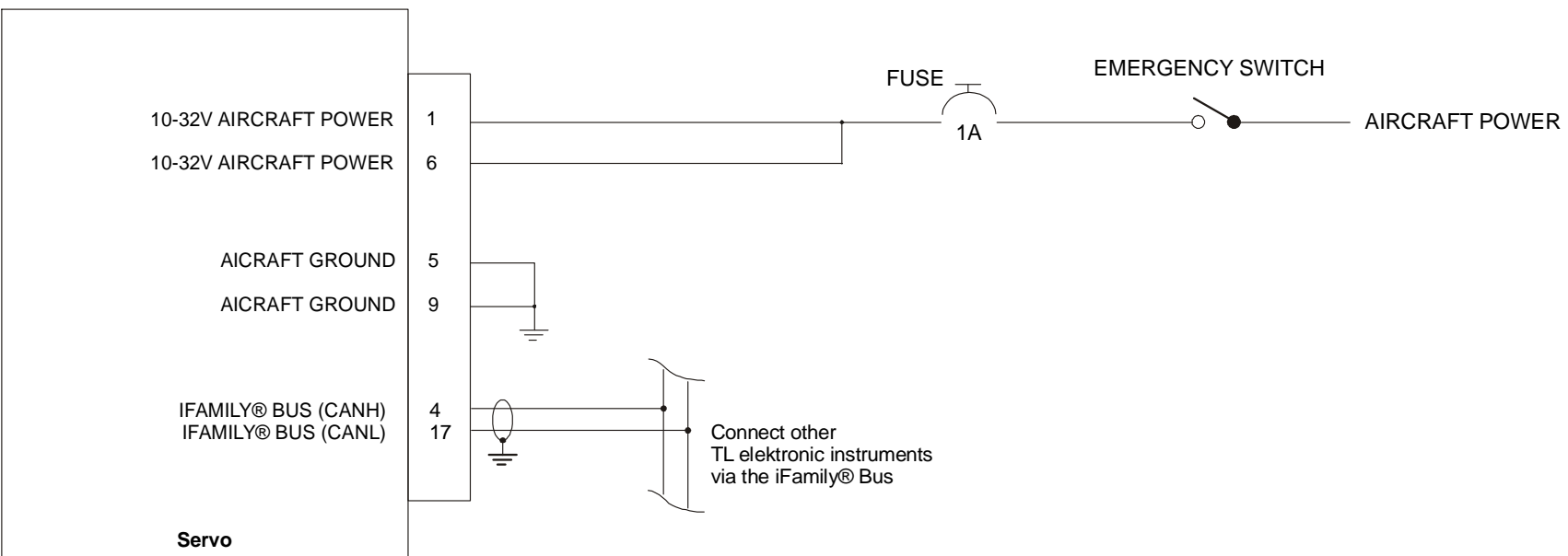

## 7 Conclusion

### **INSTRUCTIONS FOR RETURN**

If none of the above sections have helped resolve an ongoing issue with your Servo, please call TL electronic at +420 495 48 23 93 to discuss the issue with Technical Support.

In case the issue cannot be resolved, we will provide you with an RMA number to use when shipping the Servo to us. If your unit is still under warranty, the repairs will be performed and the Servo will be returned promptly. If your warranty has expired, the TL electronic representative will make arrangements with you and make you fully aware of the costs before proceeding with the repair.

While TL electronic makes every effort to save and restore your unit's settings and calibrations, we cannot guarantee that this will happen. Please note that after you receive your unit back from TL electronic with a factory calibration, the servo may be inaccurate once re-installed in your aircraft.